



42371 Avenida Alvarado
Temecula, CA 92590
TOLL FREE (800) 454-2725
TEL (951) 296-3480
FAX (951) 296-3490
www.aquauv.com

Aqua Ultraviolet

Sunami Series Pumps

1/3HP, 3/4HP, 3HP, 4HP, 5HP

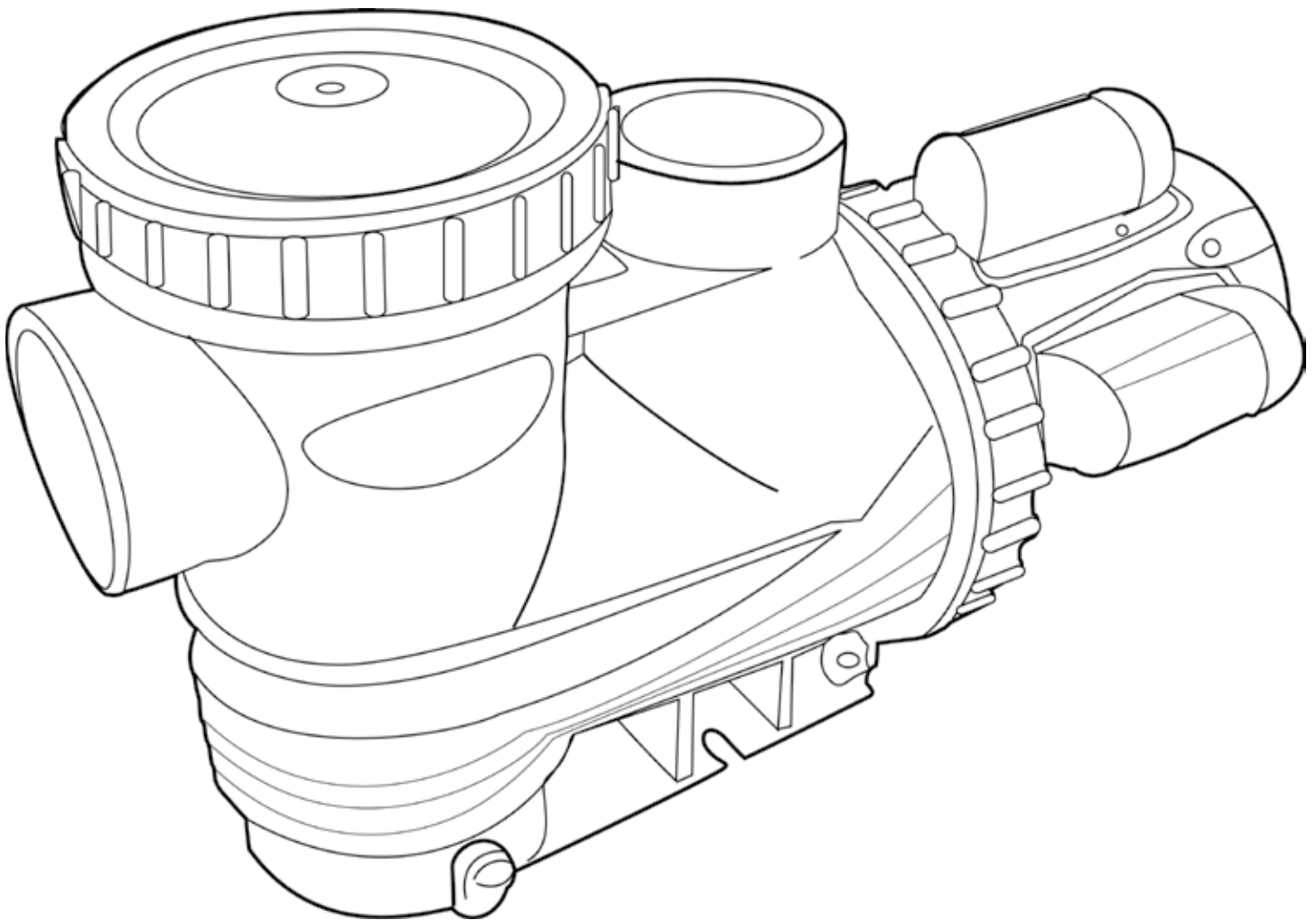

Sunami Warranty

Aqua Ultraviolet products are warranted against failure due to defects in materials and/or workmanship during the warranty period. This warranty covers defects occurring under normal use and applies to the original retail purchaser and may not be transferred. The warranty and remedies set forth herein are conditional upon proper storage, installation, use, maintenance and conformance with the applicable use. It will be based upon Aqua Ultraviolet's discretion as to whether the defects are of manufacturing origin.

This warranty does not apply to appearance or accessory items. This warranty does not include damage due to shipping and handling, transportation, unpacking, set up, installation, improper maintenance, abrasives, corrosion and /or electrolysis, incorrect line voltage, modification, abuse, misuse, neglect, accident, fire, flood, lightning, acts of God or repair or replacement of parts supplied by any other than Aqua Ultraviolet.

Any oral statements about this product made by the seller, the manufacturer, their representatives or any other party does not constitute warranties and shall not be relied upon by the user and are not part of this contract.

Neither the seller nor the manufacturer shall be liable for any injury, loss or damages, direct, incidental or consequential including but not limited to lost profits, lost sales, injury, inability to use the product and the user agrees that no other remedy is available.

Before installing, the user shall determine the suitability of the product for their intended use and the user shall assume all risk liability whatsoever in connection therewith.

To validate this warranty, mail the enclosed warranty card within 10 days of purchase along with proof of purchase (copy of sales receipt).

Warranty Period:

Complete Unit: One year from the date of purchase or 18 months from manufacturing date.

Limitations:

Warranty does not cover any malfunction from improper installation (we recommend that a licensed electrician install your system to the specifications outlined in this owners guide).

Warranty only applies to the original end user and is not transferable.

Warranty does not cover repairs done by anyone other than Aqua Ultraviolet.

Warranty is void if system is not plugged into a G.F.C.I. (Ground Fault Current Interrupter).

Warranty may not be modified by verbal statements by Aqua Ultraviolet, distributors, retailers, their agents or any other party.

Warranty covers the repair or prorated replacement of the Aqua Ultraviolet products. Aqua Ultraviolet denies all liability for any other loss including but not limited to loss of equipment, income, livestock or personal injury.

Warranty is voided by the following:

Product labels defaced or removed.

Housing has been painted.

Product is improperly installed or maintained by user or agent.

Product abused, misused or damaged by user or their agent.

Product damage caused by electrical surges, electrical spikes, electrical brown outs or improper voltage.

Electrical cord has been cut.

Unit was run without water.

Use of Anything other than parts approved by Aqua Ultraviolet.

Any implied warranty granted under state law including warranties of merchantability or fitness for a particular purpose are limited to one year from the date of purchase or 18 months from the date of manufacture or as otherwise stated in the above warranty. Aqua Ultraviolet is not responsible for direct, indirect, incidental or consequential damages. Some states do not allow limitations on how long an implied warranty lasts and/or does not allow the exclusions or limitations of incidental damages so the above limitation and exclusion may not apply to you. This warranty gives you special legal rights and you may also have other rights that vary from state to state.

Warranty Returns or Repair Returns:

Please call Aqua Ultraviolet at (800) 454-2725 for a "Return Merchandise Authorization" (RMA) number. You must have a valid RMA from an Aqua Ultraviolet customer service representative before sending any product in for warranty or repair. Please have your serial number, date of purchase and product type available when calling for an RMA number.

All warranty returns or repair returns must come freight prepaid with an RMA number clearly marked on the outside of the box. All other returns will be refused. Aqua Ultraviolet will not be liable for any shipping cost to return warranty or repair items. Include a note in the box with your RMA number, name, address, daytime phone number and brief description of the reason for return or repair.

Be sure to return product in the same packing or similar packing and insure the package (we recommend sending it UPS). If you do not have or can't locate proper packaging, please call our customer service department and we will send you packaging for a minimal charge.

Aqua Ultraviolet shall not be responsible for damage or loss done by the shipper. Nor shall Aqua Ultraviolet be responsible for merchandise that arrives damaged due to improper packaging. All claims for loss and damage must be filed by the customer with the shipper.

If the unit is found to be out of warranty we will contact you with the cost of repair. Your authorization is required prior to making any repairs.

IMPORTANT INFORMATION

WE CAN HELP YOU

Returning this product is expensive and time consuming for you, your retailer and for us, the manufacturer. Should you encounter any problems with your product, please call our toll free "HELP" line for assistance 1-800-454-2725.

PLEASE DO NOT return your product to the store! Your dealer or distributor cannot offer any warranty work or exchanges.

In the US please call

TOLL FREE 1-800-454-2725

(951) 296-3480 Outside the U.S.

THANK YOU!

Sunami Installation Instructions

Please read this manual BEFORE installing the pump.

FIGURE 1 - Pump Unit

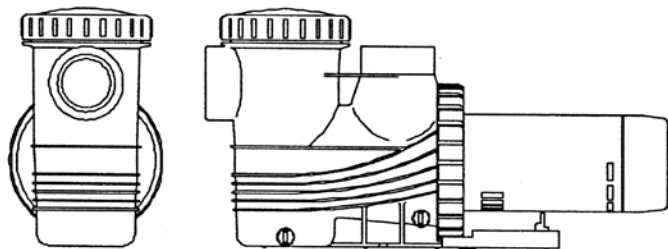

GENERAL

This is a self-priming pump, which means that it can raise water through a dry suction line without using valves, provided the pump case and strainer body are full of water before the motor is started. Nevertheless, we recommend the use of a swing check valve in the suction pipe, at or below water level. This arrangement makes the initial priming easy, and then keeps the suction pipe primed at all times. The pump is moulded from lightweight, glass-reinforced thermoplastic material which eliminates all potential corrosion problems. In addition, all surfaces in contact with water passing through the pump are insulated from the electric motor. An extension of the impeller hub forms an insulating sleeve over the motor shaft and carries the mechanical shaft seal. The strainer body is capped with a transparent cover, secured by a screw-on RING-LOK™ that provides quick and easy access for cleaning the strainer basket.

TABLE 1 - List of Models

Sunami Pumps:	Full Load Amps 110 Volt	Full Load Amps 220 Volt	GPM/GPH
Sunami 1/3 hp	4.36		100 GPM/6000 GPH
Sunami 3/4 hp	5.81		120 GPM/7200 GPH
Sunami 3 hp		16.3	183 GPM/11000 GPH
Sunami 4 hp		16.3	194 GPM/11640 GPH
Sunami 5 hp		19.8	275 GPM/16500 GPH

All Information Based on 10ft Of Head Pressure

Sunami Installation Instructions

INSTALLATION LOCATION

Locate the pump as close to the pond as possible, preferably in a dry, shaded, well-ventilated area. Install the pump at or below deck level. If this is not possible, choose the lowest available elevation. This simplifies priming, and adds to the pressure developed by the pump. Prepare a hard, level surface that is large enough to accommodate the pump and the associated equipment. Bear in mind the following:

1. drainage
2. ventilation of the motor;
3. access for servicing and winterizing the equipment
4. protection of the equipment from the elements.

GENERAL INSTALLATION INFORMATION

The pumps comes with 3" slip connectors. The 1/3 and 3/4 HP models include a 2" reducer. Never use a suction pipe smaller than the pump connection. Keep the piping as simple as possible. Avoid connecting an elbow directly to the pump inlet (use a length of straight pipe to allow a proper entry for the water). Keep as much of the suction pipe as possible below the water level of the pond because this will reduce the priming time, but arrange the pipe to rise continuously toward the pump to prevent high spots that could form air pockets. Support the pipes independently so that they place no strain on the pump. Install swing type check valves and unions in the pump suction and pond return lines close to the filter system for convenient servicing of the equipment. These valves are essential if the equipment is installed below deck. Keep the check valve in the suction line fully open during operation, and make sure that its gland is kept tight to prevent the entrance of air around the valve stem. Take care during installation to keep the pipes clean. Apply pipe sealant to all male threads, Teflon tape is recommended, and make sure that the suction system is absolutely airtight. Use of thread sealants other than Teflon tape may permanently damage the threads on the pump causing leaks. Do not use any lubricant.

Sunami Installation Instructions

ELECTRICAL CONNECTIONS

Check that the information on the nameplate of the electric motor corresponds the power supply to be used. Employ a competent electrician to ensure the wiring installation is made in accordance with Electrical Code. Every motor requires a fused disconnect switch or circuit breaker.

A SINGLE-PHASE MOTOR has built-in thermal overload protection.

OPERATION

Note: See Figure 2 for pictures of individual parts.

1. Remove the strainer cover from the strainer basket and fill the pump completely with water. Replace the cover.

CAUTION: Do not over-tighten the strainer **RING-LOK™**; hand tighten only. **DO NOT RUN THE PUMP WITHOUT WATER.**

2. Start the pump. If the pump fails to produce a full flow of water within four or five minutes, switch off the power and repeat Step 1. If the pump still fails to work, check for air leaks at the strainer cover, suction line connections, and valve stem glands before repeating Step 1.

CAUTION - DO NOT OPERATE THE PUMP WITH CLOSED SUCTION OR DISCHARGE VALVES.

3. After about ten minutes of operation, check the pond return fittings for air bubbles. A continuous flow of air indicates leaks in the suction line. Locate and correct any leaks immediately.

CAUTION - DO NOT RETIGHTEN STRAINER RING-LOK™ DURING OPERATION.

CONTROLLING THE OUTPUT

Keep the check valve in the suction line fully open during operation. Should it be necessary to control the output, use a valve in the return line.

Sunami Maintenance

CAUTION - ALWAYS DISCONNECT POWER BEFORE DOING ANY PUMP MAINTENANCE

CLEANING THE STRAINER BASKET

Switch off the power. Unscrew strainer **RING-LOK™** counter clockwise and remove the strainer cover from the strainer basket then lift it out. Clean and replace the basket. Take care to seat the basket properly. Clean the 0-ring and 0-ring seats on the cover and strainer. Refit the cover and strainer **RING-LOK™** - hand tighten only. Put the pump back into operation.

Do not use any lubricant.

DRAINING

Remove the two drain plugs. Note that the valves in the suction and return lines must be open to allow complete draining of the pump. Other provisions may be necessary for draining the filter, heater, and pipe lines.

Sunami Parts Diagram

FIGURE 2 - Components

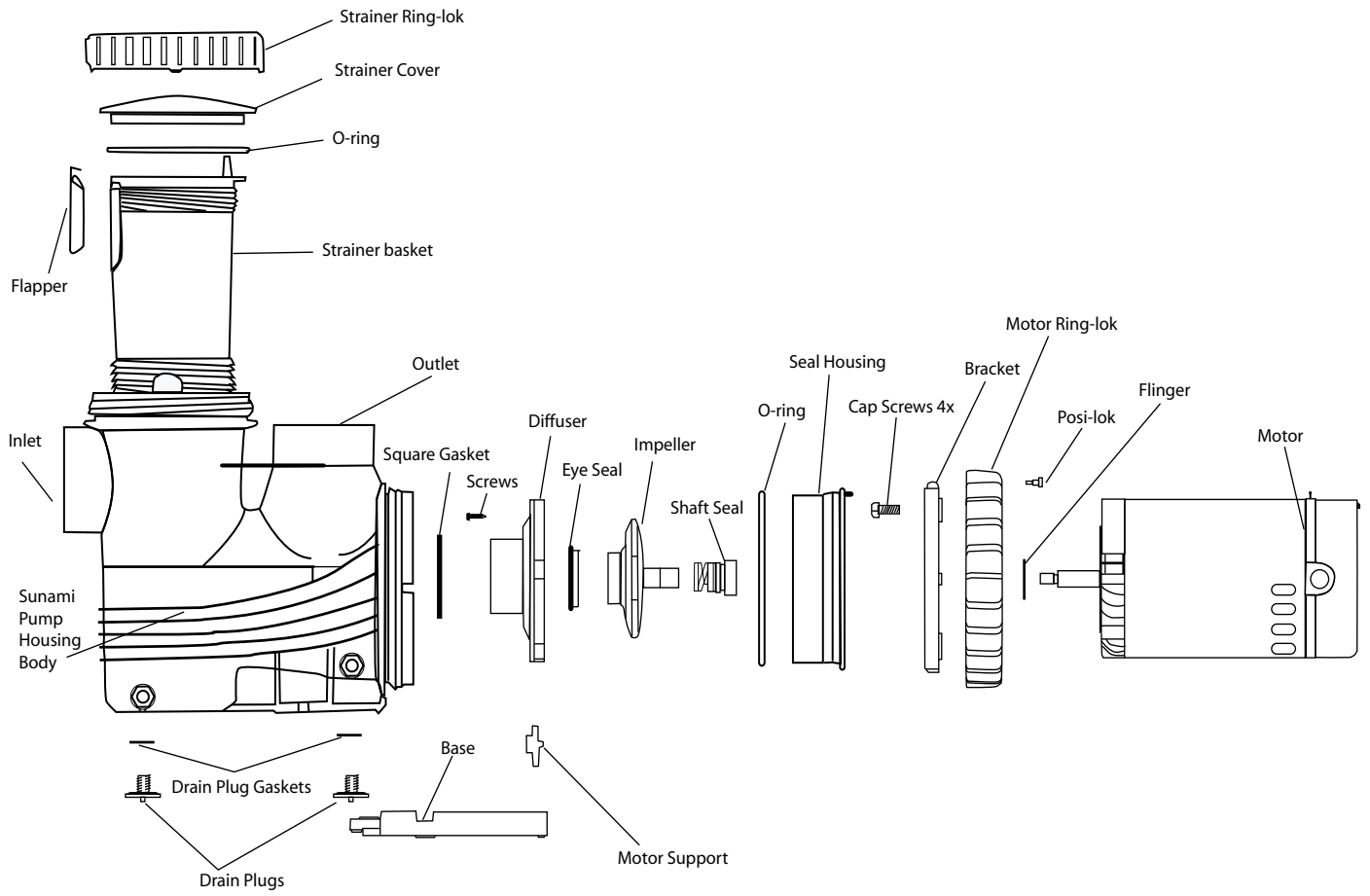

Sunami Installation Instructions

Trouble-Shooting

MOTOR DOES NOT START:

Disconnect switch or circuit breaker in OFF position
Fuses blown or thermal overload open
Locked motor shaft
Motor windings burned out
Defective starting switch inside single-phase motor
Disconnected or defective wiring

MOTOR DOES NOT REACH FULL SPEED:

Low voltage
Motor windings connected for wrong voltage

MOTOR OVERHEATS (protector trips):

Low voltage
Motor windings connected for wrong voltage
Inadequate ventilation.

PUMP DELIVERS NO WATER:

Pump not primed
Closed valve in suction or discharge line
Leakage of air into suction system
Impeller plugged.

LOW PUMP CAPACITY:

Valve in suction or discharge line partly closed
Suction or discharge line partly plugged
Suction or discharge line too small
Pump running at reduced speed (see above)
Plugged basket in skimmer or strainer basket
Dirty filter
Impeller plugged.

LOW PUMP PRESSURE

Pump running at reduced speed (see above) Discharge valve or inlet fittings opened too wide **HIGH**

PUMP PRESSURE

Discharge valve or inlet fittings closed too much
Return lines too small
Dirty filter

NOISY PUMP AND MOTOR

Plugged basket in skimmer or strainer basket
Defective motor bearings
Valve in suction line partly closed
Suction line partly plugged
Pump not supported properly

LEAKAGE OF WATER AT SHAFT

Shaft seal requires replacement

AIR BUBBLES AT INLET FITTINGS

Leakage of air into suction line at connections or valve stem
Cover of strainer basket not airtight
Restriction in suction line
Low water level in pond

AIR BUBBLES IN STRAINER BASKET

If an air bubble persists in the strainer basket, but no air bubbles are present at the pond's inlet fitting, do not be concerned. Occasionally, air is not completely flushed from the strainer of Sunami pumps.

IF THE RECOMMENDATIONS IN THE TROUBLESHOOTING PORTION OF THIS MANUAL DO NOT SOLVE YOUR PARTICULAR PROBLEM(S), PLEASE CONTACT AQUA ULTRAVIOLET FOR ADDITIONAL SUPPORT

Aqua Ultraviolet

42371 Avenida Alvarado
Temecula, CA 92590
TOLL FREE (800) 454-2725
TEL (951) 296-3480
FAX (951) 296-3490
www.aquauv.com

AQUA™
ULTRAVIOLET